

1) Louver Dampers

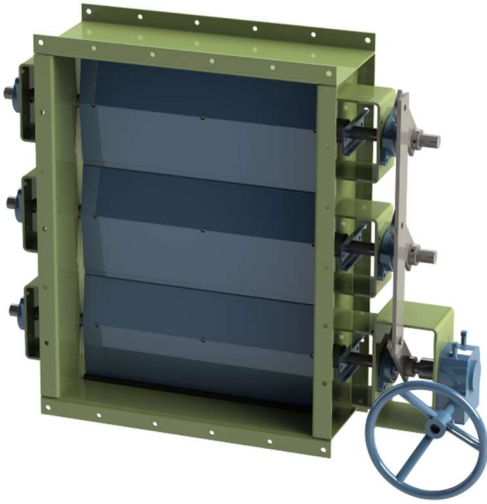

Kelair Louver Dampers or Multi-Vane Louver Dampers consist of several blades mounted parallel across a duct. They modulate the flow of air and gas in dry or wet conditions or can isolate and shut them off altogether. Opposing blade type louvers allow the flow to increase or decrease. Parallel blades allow for complete shut off and are particularly useful where space is restricted.

These dampers are frequently motorized or can be manually adjusted for flow control. Louver dampers control gas or air flow, detour flow into separate systems, or isolate a process for inspection and maintenance. They are particularly useful in applications where quick actuation and space constraints are major issues. Louver dampers are adaptable, can be lightweight, compact and have low leakage to the outside environment.

Applications

Louver dampers can withstand temperatures greater than 1800°F (with refractory) and pressures up to 1 PSI. So, they are ideal for many different industrial processes. Parallel blade louvers are ideal for scrubbers, oxidizers, precipitators, fan inlets, atmospheric exhaust, along with gas turbine inlets and outlets. Opposed blade louvers are ideal for air filtration inlets (such as dust collectors), glass or metal tempering systems, fast power generation, and discharge outlets for fans.

2) Wafer Dampers

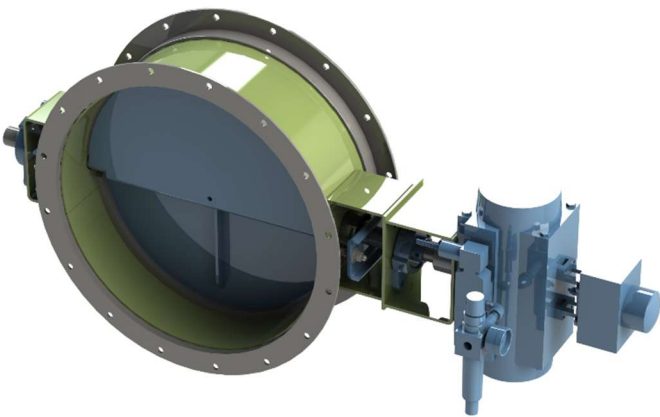

Wafer dampers are an economical industrial damper which can be used in most applications. Appropriate for flow control and low leakage in systems that regulate clean air, gas, or light particulate. Kelair's Butterfly dampers can also be engineered to process highly corrosive, abrasive, or high heat air flows. These types of dampers can be a cost-effective means to control and isolate in air duct systems. Kelair's Butterfly dampers are applicable for open-closed service or flow control balancing. Discover the variety of industrial-grade damper products available at Kelair.

Applications

Wafer dampers are diverse in their ideal applications and are commonly used to control flow within low leakage and isolation applications. Wafer dampers can be designed to withstand extreme pressures, and with refractory, can withstand very high temperatures as well (up to 1800°F). This gives them the ability to keep pressure drops low and efficiency high. Wafer dampers are great for use in corrosive environments and abrasive air streams, which make them idea for wastewater treatment applications and environmental controls.

Distributed
by:



Ph: 612-331-1776
www.duncanco.com

Kelair Dampers | 2501 Van Buren | Bellwood, IL | 60104-2459

3) Backdraft Dampers

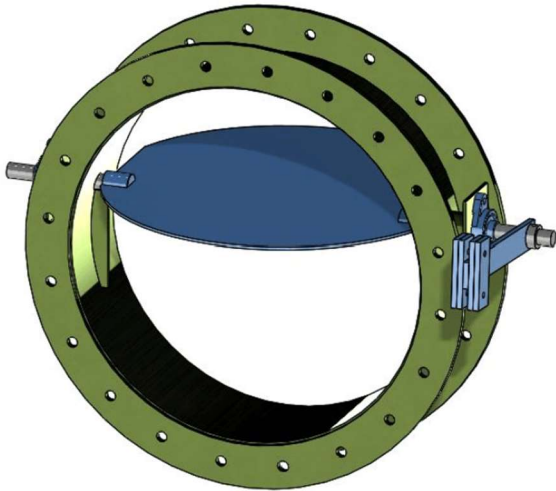

Industrial backdraft dampers fulfill the same mission as their commercial counterparts: they allow airflow in one direction and prevent airflow in the opposite direction. Another way to say this is that backdraft dampers allow for air intake or exhaust/pressure relief while automatically preventing the backflow of air. Kelair's backdraft dampers are manufactured to withstand environments with high back pressures and high airflow velocities. These types of industrial dampers can be supplied with counterbalanced weights, mounted externally that are easily field adjustable or they can be gravity balanced.

Applications

Backdraft dampers have their niche in the industrial space, such as refineries, steel mills, and utility mills. This is because these processes require significant exhaust for their process, along with pressure relief and ventilation.

4) Diverter or Bypass Dampers



A Diverter or Tee damper can be a very simple tool with 1 purpose: to divert the flow of air or gas within a system in another direction. It is typically arranged as a dual damper that resembles a Pipe-T, however it can also be configured at 45 degrees or as a "Pant Leg" version. The 2 openings or outlets are mechanically linked so that when one is opened, the other is closed. The use of one actuator with a slave linkage saves cost and assures simultaneous operation of both dampers in the assembly. Spring assisted actuators can be utilized to provide a predetermined fail position of the damper vanes. Open/closed auxiliary limit switches are also available.

Tee/Diverter can also perform the trifecta of damper functions: modulate, divert and isolate air or gas flow. This is done by adding a modulation actuator to allow diversion to multiple outlets. In fact, Kelair can manufacture a 3 or 4 way diverter damper which has up to 4 outlets, that runs all 3 of these operations: modulation, diversion and isolation.

Applications

Diverter dampers are commonly used within cogeneration units for waste heat recovery boilers. It is also common to use diverter dampers in air pollution control systems for gas power generation exhausts and heat recovery systems. Diverter dampers are ideal to redirect high-temperature gasses or air from turbines to recover heat or to bypass a process in case of emergency to meet NFPA code.

Distributed
by:



Ph: 612-331-1776
www.duncanco.com

Kelair Dampers | 2501 Van Buren | Bellwood, IL | 60104-2459

5) Inlet Vane Dampers

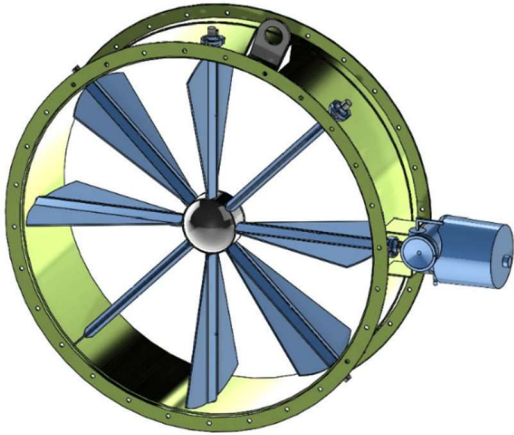

The Inlet Vane Damper is an ideal way to improve performance and efficiency within industrial applications. Vane dampers (also known as Variable Inlet Vane Damper (VIV), Inlet Vane Control Damper (IVC), Radial Inlet Vane Damper, and Vortex damper among others) perform the same basic function: they pre-spin air, in the same direction as the fan rotation, before it enters the fan inlet. This directed air reduces the load on the fan by lowering the fan pressure and airflow. This in turn reduces the energy necessary to operate the fan. Inlet vane dampers reduce the energy costs necessary to operate fans, enhance their performance and provide long term savings.

Kelair's Inlet Vane dampers have a central hub surrounded by multiple blades and are used primarily in clean air/gas environments without particulates and able to withstand temperatures up to 2000 degrees F. Inlet Vane dampers are appropriate for both volume control and fan shutoff. This damper has the added benefit of easily allowing field changeable air pre-spin rotation. Designed and engineered for easy maintenance and service, there is no need to remove the Kelair Inlet Vane damper from the fan as it is built to take high airflow velocities.

Applications

Inlet vane dampers are ideal for facilities that need to have complete control of their ventilation; such as flue gas, automotive, and oven recirculation systems. They are also ideal to maximize fan life, reduce fan energy costs, and increase fan efficiency.

6) Guillotine Dampers

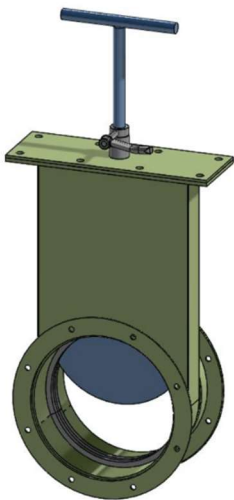

Slide gate dampers or guillotine dampers are a type of industrial damper commonly used when low leakage and low-pressure drop are required. They perform best where flow control is not critical but low leakage is. These types of dampers are well suited for situations where isolation of an air stream or gas flow occurs frequently due to routine maintenance, inspection or repair. Kelair's heavy duty construction allows for slide gate or guillotine dampers to function reliably in demanding environments with corrosive gas, particulates and high temperature.

Kelair's slide gate dampers provide numerous benefits to your application. They cut through heavy particulates with smooth opening and closing. They have fewer moving parts, therefore less maintenance. If space is an issue, guillotine dampers require less of it along the duct (flange to flange). Overall, slide gate or guillotine dampers benefit the customer with solid, long term operational savings.

Applications

Guillotine dampers are typically used in isolation applications such as scrubber inlet/outlet, flue gas clean up, isolation in the stack, precipitator isolation, and wastewater treatment facilities.

Distributed
by:

DUNCAN CO

Ph: 612-331-1776
www.duncanco.com