

Cast Steel Float & Thermostatic Steam Trap FT450

Steam Traps
Float & Thermostatic

The trap contains a float valve mechanism which modulates to discharge condensate continuously at steam temperature, while non-condensable gases are released by a separate internal balanced pressure thermostatic air vent.

Model	FT 450 (Replaces FT 32)
PMO	465 psig (see below)
Sizes	3/4" to 2"
Connections	NPT Carbon Steel Body
Construction	Stainless Steel Internals
Options	ANSI 150, 300 or 600 RF flanged SW Connections to ANSI B16.11 Bimetal Air Vent on 4.5, 10, 14, and 21 Drain plug tapped 1/2" NPT models for superheat operation.

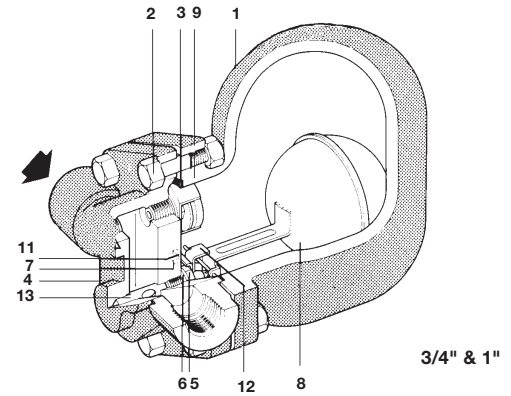

Construction Materials

No.	Part	Material	
1	Body	Cast Steel	ASTM A216 WCB
2	Cover Bolts	Alloy Steel	ASTM A 193 B7
	Cover Nuts 3/4" & 1"	7/16 - 14 UNC-2A	ASTM A 194 2H
	1-1/2" & 2"	5/8-11UNC-2A	
3	Cover Gasket	Exfoliated Graphite	
4	Cover	Cast Steel	ASTM A216 WCB
5	Valve Seat (3/4" & 1")	Stainless Steel	
	Main Valve Assembly w/ erosion deflector (1-1/2" & 2")	Stainless Steel	
6	Valve Seat Gasket (3/4" & 1")	Stainless Steel	
	Main Valve Assy Gasket 1-1/2" & 2"	Stainless Steel Reinforced Exfoliated Graphite	
7	Pivot Frame Assy	Stainless Steel	
	Set Screws (3/4" & 1")	10-24 Fillister Head	
	Main Valve Assembly Cap Screws (1-1/2")	1/4-20	
	Studs & Nuts (2")	5/16-18	
8	Ball Float & Lever	Stainless Steel	
9	Air Vent Assembly	Standard Stainless Steel	
9A	Optional Bimetal	Corrosion resistant Bimetal and Stainless Steel	
10	Air Vent Seat Gasket	Stainless Steel	
11	Support Frame	Stainless Steel	
12	Pivot Frame	Stainless Steel	
13	Erosion Deflector	Stainless Steel	

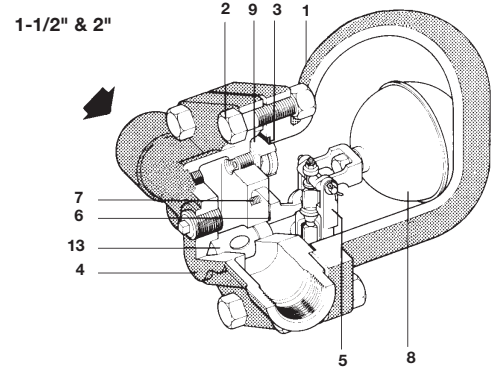

Capacities: See TIS 2.308

Limiting Operating Conditions*

Max. Operating Pressure (PMO)	FT450-4.5:	65 psig (4.5 barg)
	FT450-10:	145 psig (10 barg)
	FT450-14:	200 psig (14 barg)
	FT450-21:	300 psig (21 barg)
	FT450-32:	465 psig (32 barg)
Max. Operating Temperature	Bimetal optional air vent	650°F (343°C) at 450 psig
	750°F (400°C) at opening pressures below 505 psig	

Pressure Shell Design Conditions For NPT, SW, ANSI300, ANSI600*

PMA	535 psig/650°F	37 barg/342°C
Max. allowable pressure	505 psig/750°F	35 barg/400°C

TMA	750°F/0-505 psig	400°C/0-34 barg
-----	------------------	-----------------

* The limiting operating and design conditions for ANSI 150 flanged units will be limited by the Flange Rating.

Typical Applications

All process equipment, particularly when controlled by modulating temperature control valves; unit heaters, air heating coils, heat exchangers and steam main drip stations.

Thermostatic Air Vent Operating Range

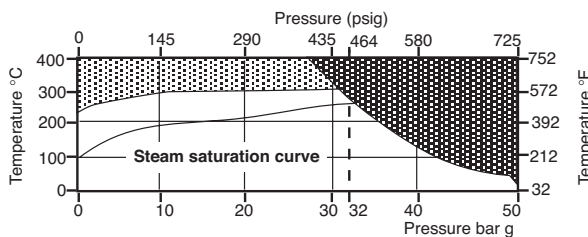

The product must not be used in this region.

The product must not be used in this region as damage to internals may occur.

Local regulation may restrict the use of this product below the conditions quoted. Limiting conditions refer to standard connections only.

In the interests of development and improvement of the product, we reserve the right to change the specification.

TI-2-304-US 03.14

Cast Steel Float & Thermostatic Steam Trap FT450

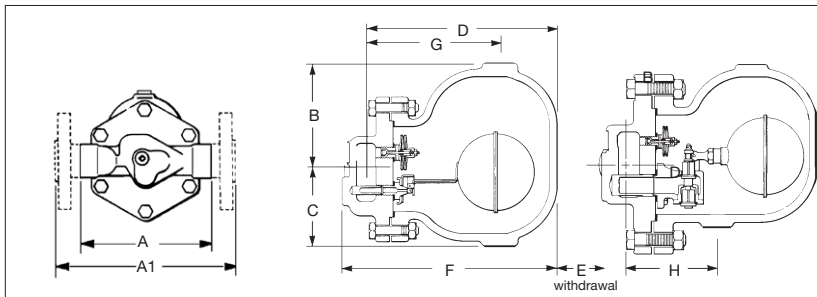

Dimensions (nominal) in inches and millimeters

Size-DN	A	A1	B	C	D	E	F	G	H	NPT/SW	Flg
3/4" 20	6.1 155	10.1 255	3.0 76	3.1 79	6.4 163	4.7 120	7.4 189	4.0 102	—	18.0 lb 8.2 kg	23.8 lb 10.8 kg
1" 25	6.5 165	10.4 264	5.0 127	3.8 97	8.2 208	6.3 160	9.2 234	5.8 147	—	28.0 lb 12.7 kg	33 lb 15 kg
1-1/2" 40	9.8 250	14.0 356	5.6 142	3.6 92	9.8 250	7.7 195	11.1 282	6.4 163	4.7 119	55.1 lb 25.0 kg	64.0 lb 29.0 kg
2" 50	11.8 300	16.0* 406*	6.0 152	4.0 102	10.0 255	7.7 195	11.6 295	6.5 165	6.0 152	68.0 lb 31.0 kg	82.0 lb 37.3 kg

*ANSI 600 16.5" 419 mm

Maintenance

This product can be maintained without disturbing the piping connections. Complete isolation from both supply and return line is required before any servicing is performed. The trap should be disassembled periodically for inspection and cleaning of the valve head and seat, operating mechanism and air vent.

Worn or damaged parts should be replaced using a complete valve mechanism assembly and/or air vent assembly.

Complete installation and maintenance instructions are given in IMI 2.300, which accompanies the product.

Sample Specification

Steam traps shall be of the mechanical ball float type having steel bodies, horizontal line connections, and stainless steel valve heads, seats and ball floats. Incorporated into the trap body shall be a stainless steel balanced pressure thermostatic air vent capable of withstanding 45°F(25°C) of superheat and resisting waterhammer without sustaining damage. The FT450-32 shall have a bimetal air vent. Internals of the trap shall be completely servicable without disturbing the piping.

Installation

A pipeline strainer should be installed ahead of any steam trap. Full port isolating valves should be placed to permit servicing. The trap should be installed below the drainage point of the equipment with a collecting leg before the trap, in a position so that the float arm is in a horizontal plane and the float rises and falls vertically, with the flow direction as indicated on the body. Refer to IMI 2.300 for complete instructions.

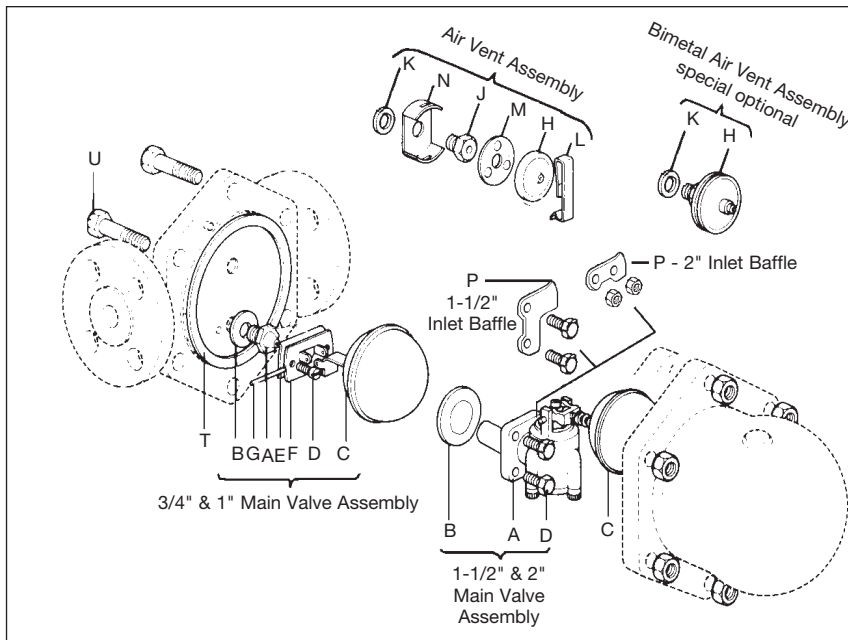

Spare Parts

Valve Mechanism Kit w/ Float (3/4" & 1")	A,B,C,D,E,F,G
Valve Mech. Kit (1-1/2" & 2")	A,B,D,P
Air Vent Kit (PMO up to 21 bar)	H,J,L,M,N
Air Vent Kit (PMO 32 bar)	H,K
Gasket Kit (3 of each)	B,K,T
Ball Float (1-1/2" & 2")	C

The erosion deflector is pressed into the body during manufacture and not available as a spare.

TI-2-304-US 03.14