



Features

- Internal electronic feedback maintains precise output pressure control.
- Piezoelectric actuator disk provides stability regardless of vibration or position.
- RFI/EMI protection eliminates susceptibility to electromagnetic interference.
- Field selectable outputs in three pressure ranges match final control element requirements.
- Field reversible feature provides output that is directly or inversely proportional to input signal.
- Does not contain copper-based metals.
- Compact size for use in restricted areas.
- Damping adjustment allows tuning for optimum response.
- Optional version approved for use with Natural Gas or Industrial Methane as a supply media.
- Explosion-proof NEMA 4X, IP65, Type 4 enclosure for outdoor and indoor installations.
- Optional tapped exhaust port vents exhaust gas.
- Canadian Registration Numbers (CRN) certification for all territories and provinces.
- All TXI7800 products are ROHS compliant.

Operating Principles

The Model TXI7800 Transducer is an electronically controlled pressure sensitive device that converts a current signal to a pneumatic output. This device is composed of the Primary Converting Section and the Relay Section. The Piezoelectric ceramic disk in the Primary Section functions as a flapper. The flapper and the nozzle work together to control the signal pressure in the Relay Section. The signal pressure acts on a diaphragm assembly that controls the pressure in the output chamber.

The output pressure is sensed by the lower control diaphragm to maintain the output pressure. The output pressure is also sensed by the feedback control circuit, which compares the output pressure and input signal (setpoint) to maintain constant output pressure.

The Damping Adjustment on the PC Board allows tuning the transducer for optimum response and stability. Large downstream volumes generally require more damping to achieve output pressure stability.

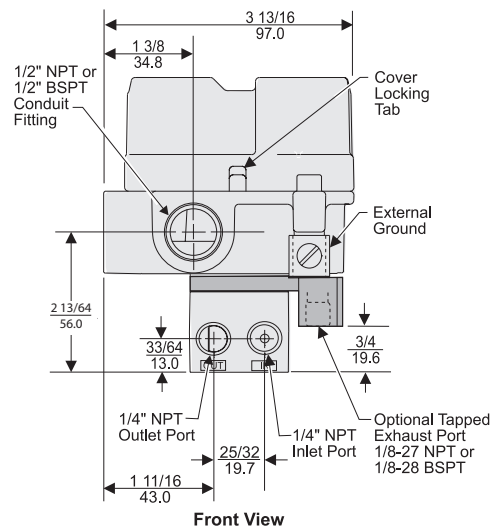
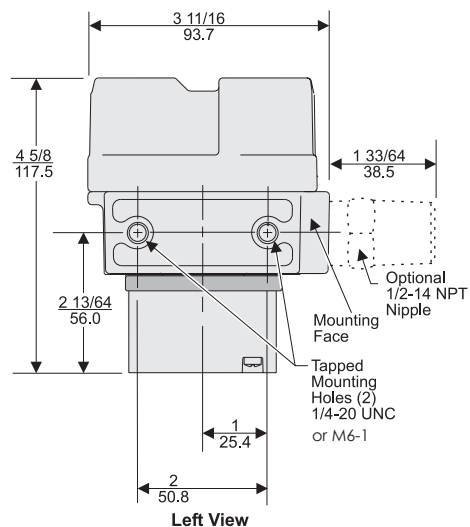
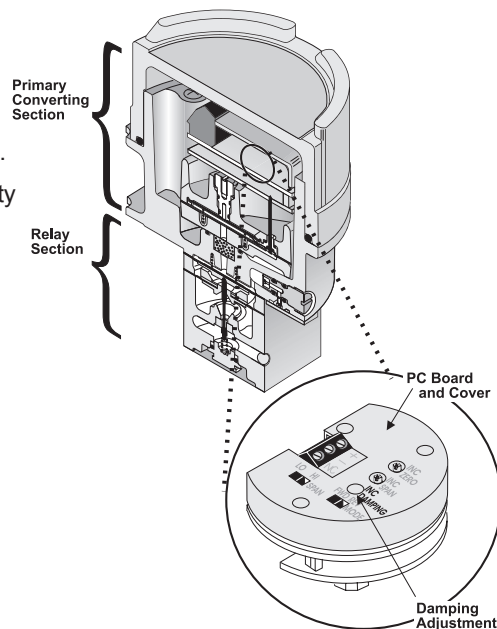

Distributed by:

DUNCAN CO

www.duncanco.com

612-331-1776

Model TXI7800 Explosion-Proof Transducer

Specifications

		SET POINT							
		3 [0.2] (20)		9 [0.6] (60)		15 [1.0] (100)		30 [2.0] (200)	
Maximum Air Consumption	All Ranges SCFH	1 (0.03 m ³ /HR)	1.3* (0.04 m ³ /HR)	1.9 (0.05 m ³ /HR)	2.5* (0.07 m ³ /HR)	2.5 (.07 m ³ /HR)	3.2* (0.09 m ³ /HR)	4.2 (0.12 m ³ /HR)	5.4* (0.15 m ³ /HR)
Flow Rate (SCFM)		2.5 (4.25 m ³ /HR) @ 25 psig, [1.7 BAR], (170 kPa) supply & 9 psig, [0.6 BAR], (60 kPa) Output				OR	9.0 (15.3 m ³ /HR) @ 120 psig, [8.0 BAR], (800 kPa) supply & 9 psig, [0.6 BAR], (60 kPa) Output		
Temperature Range	Operating Storage	-40°F to + 160°F (-40°C to + 71.2°C) -40°F to + 180°F (-40°C to + 82.2°C)							
Span/Zero Adjustments		Screwdriver adjustments located under cover							
		OUTPUT RANGE							
		3-15 [0.2-1.0] (20-100)		3-27 [0.2-1.8] (20-180)		6-30 [0.4-2.0] (40-200)			
Input Range		4-20 mA							
Supply Pressure ^{1,2}		20-120 [1.5-8.0] (150-800)		32-120 [2.2-8.0] (220-800)		35-120 [2.4-8.0] (240-800)			
Minimum Span		5 [0.35] (35)		10 [0.7] (70)		10 [0.7] (70)			
Frequency Response		-3 db @ 5 Hz per ISA S26.4.3.1 load configuration A.							
Required Operating Voltages		8.2 VDC @ 20 mA (4-20 mA signal)							
Accuracy (ISA S51.1)		0.25% Full Scale Guaranteed 0.15% Full Scale Typical							
Hysteresis (ISA S51.1)		≤ 0.1% Full Scale							
Deadband		≤ 0.02% Full Scale							
Repeatability (ISA S51.1)		≤ 0.1% Full Scale							
Position Effect		No Measurable Effect							
Vibration Effect		Less than +1% of Span under the following conditions: 5-15 Hz @ 0.75 inches constant displacement 15-500 Hz @ 10 Gs.							
Reverse Polarity Protection		No damage occurs from reversal of normal supply current (4-20 mA) or from misapplication of up to 60 mA.							
RFI/EMI Effect		Less than 0.5% of span @ 30 μ m class 3 Band ABC (20-1000 mHz) per SAMA PMC 33.1 1978 and less than 0.5% of Span @ 10 μ m level, to 2 GHz Band per EN 61000-4-3:1998 +A1 EMC Directive 89/336/EEC European Norms EN 61326							
Supply Pressure Effect		No Measurable Effect							
Temperature Effect		[+0.5% +0.04% / °F Temperature Change] of Span typical							
Materials of Construction		Body and Housing Chromate Treated Aluminum Orifice Aluminum & Sapphire Trim Stainless Steel & Zinc Plated Steel Elastomers Nitrile Finish Epoxy Powder Coating							

B

Model
TXI
7800

Explosion Proof

¹ Supply Pressure must be no less than 5 psig, [0.35 BAR], (35 kPa), above maximum output.

² Unit with "N" option 125 psig, [8.5 BAR], (850 kPa) for air or Group IIA Gases.

*With Natural Gas Media

Model TXI7800 Electro-Pneumatic I/P, E/P Transducer

Extended Range Specifications

		SET POINT									
		0 [0] (0)		15 [1.0] (100)		30 [2.0] (200)		60 [4.0] (400)		120 [8.0] (800)	
Maximum Air Consumption	0-30 psig SCFH	1 (0.03 m ³ /HR)	1.3* (0.04 m ³ /HR)	2.8 (0.08 m ³ /HR)	3.6* (0.10 m ³ /HR)	4.2 (0.12 m ³ /HR)	5.4* (0.15 m ³ /HR)				
	0-60 psig SCFH	1.6 (0.4 m ³ /HR)		4.7 (.13 m ³ /HR)		7.8 (.22 m ³ /HR)		13.3 (.37 m ³ /HR)			
	0-120 psig SCFH	0.5 (.01 m ³ /HR)				3.8 (.11 m ³ /HR)		7.6 (.21 m ³ /HR)		15.1 (.42 m ³ /HR)	
Flow Rate (SCFM)		11.0 (18.7 m ³ /HR) @ 150 psig, [10 BAR], (1000 kPa) supply & midscale output									
Temperature Range	Operating Storage	-40°F to + 160°F, (-40°C to + 71.2°C) -40°F to + 180°F, (-40°C to + 82.2°C)									
Span/Zero Adjustments		Screwdriver adjustments located on front of unit									
Required Operating Voltages		Two Wire Current Input 8.2 VDC @ 20 mA (4-20 mA signal)									
Signal Impedance		Three Wire Voltage Input 10 Kilohms									

		OUTPUT RANGE		
		0-30 [0-2.0] (0-200)	0-60 [0-4.0] (0-400)	0-120 [0-8.0] (0-800)
Input Range		4-20 mA DC		
Supply Pressure ^{1,2}		35-150, [2.4-10], (240-1000)	65-150, [4.6-10], (460-1000)	125-150, [8.8-10], (880-1000)
Minimum Span		12.5 [0.85] (85)	25 [1.5] (150)	50 [3.0] (300)
Frequency Response		-3 db @ 2 Hz per ISA S26.4.3.1 load configuration A.		
Accuracy (ISA S51.1)		0.25% Full Scale Guaranteed 0.15% Full Scale Typical		
Hysteresis (ISA S51.1)		0.25% Full Scale		
Deadband		0.02% Full Scale		
Repeatability (ISA S51.1)		0.1% Full Scale		
Position Effect		0.125% @ 90° & 0.25% @ 180°		
Vibration Effect		Less than +1% of Span under the following conditions: 5-15 Hz @ 0.8 inches constant displacement 15-500 Hz @ 10 Gs.		
Reverse Polarity Protection		No damage occurs from reversal of normal supply current (4-20 mA) or from misapplication of up to 60 mA.		
RFI/EMI Effect		Less than 0.5% of span @ 30 1/m class 3 Band ABC (20-1000 mHz) per SAMA PMC 33.1 1978 and less than 0.5% of Span @ 10 1/m level, to 2 GHz Band per EN 61000-4-3:1998 +A1 EMC Directive 89/336/EEC European Norms EN 61326		
Supply Pressure Effect		< 0.1 psig change for 10 psig supply change		
Temperature Effect		[+0.5% +0.06% / °F Temperature Change] of Span typical		
Materials of Construction		Body and Housing Chromate Treated Aluminum Orifice Nickel Plated Brass & Sapphire Trim Stainless Steel & Zinc Plated Steel Elastomers Nitrile Finish Epoxy Powder Coating		

B
Model
TXI
7800
Explosion Proof



¹ Supply Pressure must be no less than 5 psig, [0.35 BAR], (35 kPa), above maximum output

² Unit with "N" option 125 psig, [8.5 BAR], (850 kPa) for air or Group IIA Gases.

*With Natural Gas Media

Model TXI7800 Explosion-Proof Transducer

Hazardous Area Classifications

	Explosion-Proof	Intrinsically Safe											
Factory Mutual (FM) Approvals 	Air as supply pressure media Class I, Division 1, Groups B, C and D; Class II, Division 1, Groups E, F and G; Class III, Division 1, Fibers; Class I, Division 2, Groups A, B, C and D; Max. Ambient 65°C; Temperature Code T5; NEMA 4X Enclosure.	Air as supply pressure media Class I, II, III, Division 1, Groups C, D, E, F & G, Fibers NEMA 4X Enclosure; Temperature Code T4 (Ta -40°C to +80°C, Entity) 1/0 AEx ia IIB T4 (Ta -40°C to +80°C)											
	Group D gases, including Natural Gas as supply pressure media Class I, Division 1, Groups C and D; Class II, Division 1, Groups E, F and G; Class I, Division 2, Groups A, B, C and D; Class II, Division 2, Groups E, F and G.	Entity Parameters <table border="1"> <tr> <td>V_{max}¹ = 30 VDC</td> <td>C_i³ = 0</td> </tr> <tr> <td>I_{max}² = 200 mA</td> <td>L_i⁴ = 0</td> </tr> <tr> <td>¹V_{max} = Max. Voltage</td> <td>³C_i = Capacitance</td> </tr> <tr> <td>²I_{max} = Max. Current</td> <td>⁴L_i = Inductance</td> </tr> </table>	V _{max} ¹ = 30 VDC	C _i ³ = 0	I _{max} ² = 200 mA	L _i ⁴ = 0	¹ V _{max} = Max. Voltage	³ C _i = Capacitance	² I _{max} = Max. Current	⁴ L _i = Inductance			
V _{max} ¹ = 30 VDC	C _i ³ = 0												
I _{max} ² = 200 mA	L _i ⁴ = 0												
¹ V _{max} = Max. Voltage	³ C _i = Capacitance												
² I _{max} = Max. Current	⁴ L _i = Inductance												
Canadian Standards Association (CSA) Approvals 	Air as supply pressure media Class I, Division 1, Groups B, C and D; Class II, Division 1, Groups E, F and G; Class I, Division 2, Groups A, B, C and D; Class II, Division 2, Groups E, F and G. Max. Ambient 65°C Temperature Code T5; Type 4X Enclosure.	Air as supply pressure media Class I, Division 1, Groups C and D; Class II, Division 1, Groups E, F and G; Temperature Code T4A (Ta -40°C to +66°C); T6 (Ta -40°C to +40°C). Rated 4-20 mA, 30 VDC maximum Type 4X Enclosure											
	Group D gases, including Natural Gas as supply pressure media Class I, Division 1, Groups C and D; Class II, Division 1, Groups E, F and G; Class I, Division 2, Groups A, B, C and D. Class II, Division 2, Groups E, F and G.	Approvals are valid when connected through a Shunt Zener Diode Safety Barrier meeting the following parametric requirements: <table border="1"> <tr> <td>System Type 1:</td> <td>Single Channel Polarized Rated: 28.5V Max. 300 Ohm Min.</td> </tr> <tr> <td>System Type 2:</td> <td>Dual Channel Polarized Rated 28.5V Max. 300 Ohm Min. and 28V Diode return per channel</td> </tr> <tr> <td>System Type 3:</td> <td>Dual Channel Polarized Rated: 28.5V Max. 300 Ohm Min. and 10V Max. 50 Ohm Min.</td> </tr> </table>	System Type 1:	Single Channel Polarized Rated: 28.5V Max. 300 Ohm Min.	System Type 2:	Dual Channel Polarized Rated 28.5V Max. 300 Ohm Min. and 28V Diode return per channel	System Type 3:	Dual Channel Polarized Rated: 28.5V Max. 300 Ohm Min. and 10V Max. 50 Ohm Min.					
System Type 1:	Single Channel Polarized Rated: 28.5V Max. 300 Ohm Min.												
System Type 2:	Dual Channel Polarized Rated 28.5V Max. 300 Ohm Min. and 28V Diode return per channel												
System Type 3:	Dual Channel Polarized Rated: 28.5V Max. 300 Ohm Min. and 10V Max. 50 Ohm Min.												
Explosive Atmospheres Directive (ATEX) Approvals	Flame-Proof Air as supply pressure media Ⓢ II 2 GD EEx d IIB + H ₂ , T5 (-20°C to +65°C) Ambient; IP65 Enclosure. 02ATEX1014 Group IIA gases, including Natural Gas as supply pressure media Ⓢ II 2 GD EEx d IIB, T5 (-20°C to +65°C) Ambient; IP65 Enclosure. 02ATEX1014	Intrinsically Safe Air as supply pressure media Ⓢ II 1 GD Ex ia IIB T4 Ga Ex ia D20 T90°C Da; Ta=-40°C to +80°C IP65 Enclosure. 11ATEX2161X V _i =28V I _i =100mA P _i =0.7W C _i =0 L _i =0											
	IECEx Approvals	Transducer Parameters <table border="1"> <tr> <td>U_i¹ = 28 V</td> <td>P_i³ = 0.7 W</td> <td>L_i⁵ = 0</td> </tr> <tr> <td>I_i² = 100 mA</td> <td>C_i⁴ = 0</td> <td></td> </tr> <tr> <td>¹U_i = Max. Voltage</td> <td>³P_i = Max. Power</td> <td>⁵L_i = Inductance</td> </tr> <tr> <td>²I_i = Max. Current</td> <td>⁴C_i = Capacitance</td> <td></td> </tr> </table> TEXI7800 Ex ia IIB T4 Ga Ex ia D20 T90C Da; Ta=-40°C to +80°C IECEx SIR 11.0074X IP65 Enclosure	U _i ¹ = 28 V	P _i ³ = 0.7 W	L _i ⁵ = 0	I _i ² = 100 mA	C _i ⁴ = 0		¹ U _i = Max. Voltage	³ P _i = Max. Power	⁵ L _i = Inductance	² I _i = Max. Current	⁴ C _i = Capacitance
U _i ¹ = 28 V	P _i ³ = 0.7 W	L _i ⁵ = 0											
I _i ² = 100 mA	C _i ⁴ = 0												
¹ U _i = Max. Voltage	³ P _i = Max. Power	⁵ L _i = Inductance											
² I _i = Max. Current	⁴ C _i = Capacitance												

B
 Model TXI 7800
 Explosion Proof

Mounting Kit

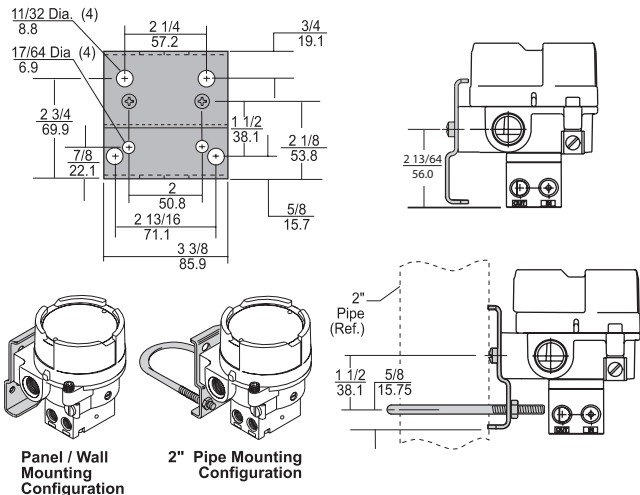

Model TXI7800 Transducer Kits & Accessories

Mounting Bracket Kits

- 19021-1: TCXI7800, TFXI7800 (sold separately)
- 19021-2: TEXI7800, TAXI7800 (sold separately)

Catalog Information

Catalog Number T X I 7800

Underwriting Group

Canadian Standard
ATEX
Factory Mutual

C
E
F

Temperature Range

-40°F to +160°F

0

Input

4-20 mA

4

Output

- 3-15 psig
- 3-27 psig
- 6-30 psig
- 0-30 psig
- 0-60 psig
- 0-120 psig

01
02
03
04
05
06

- [0.2-1.0 BAR]
- [0.2-1.8 BAR]
- [0.4-2.0 BAR]
- [0-2.0 BAR]
- [0-4.0 BAR]
- [0-8.0 BAR]

11
12
13
14
15
16

- (20-100 kPa)
- (20-180 kPa)
- (40-200 kPa)
- (0-200 kPa)
- (0-400 kPa)
- (0-800 kPa)

21
22
23
24
25
26

Options

- Tapped Exhaust
- Natural Gas media approval, Group D gases ⁴
- (Includes Nipple; TCXI, TEXI, TFXI only) ^{1,2}
- BSPT Thread ³

E
N
U

- 20 ft cable length⁴
- 50 ft cable length⁴
- 100 ft cable length⁴

2
5
0

¹ Not approved for Intrinsically Safe.

² Tapped Exhaust option required.

³ Available for ATEX only. NOT available with "N" Option.

⁴ 10 ft cable standard. Longer lengths available. Contact factory for details and availability.

Installation

For installation instructions, refer to the *Fairchild Model TXI7800 Explosion-proof Electro-pneumatic Transducer Installation, Installation Instructions, II-5TXI7800.*

For operation and maintenance instructions, refer to the *Fairchild Model TXI7800 Explosion-proof Electro-pneumatic Transducer Operation and Maintenance Instructions, OM-5TXI7800.*

B
Model
TXI
7800
Explosion Proof